

EVS27
Barcelona, Spain, November 17-20, 2013

Ultracapacitors in micro-and mild hybrids with lead-acid batteries: Simulations and laboratory and in-vehicle testing

Andrew Burke, Marshall Miller, Hengbing Zhao, Michael Radenbaugh, Zhengmao Liu
Institute of Transportation Studies,
University of California, Davis California 95616 USA

Abstract

This paper describes work directed toward the demonstration of ultracapacitors in a 2001 Honda Insight. The general approach used in this project is to replace the NMH battery with ultracapacitor modules maintaining the 12V lead-acid battery to power the accessories. Both the ultracapacitors and the 12V battery will be recharged from the electric motor/generator driven by the engine. The Insight is being modified so that it can operate as a stop-start hybrid with and without power assist and as a mild hybrid using the full power capability of its 10 kW electric motor. In the case of the start-stop hybrid, the modified Insight will use 16V ultracapacitor modules; in the case of the mild hybrid, the vehicle will use 48V modules as part of a 176V electric driveline. The energy storage units have been tested in the laboratory using cycles appropriate for the vehicle tests. The energy storage and maximum power capability of each of the storage units was found to be sufficient to meet the project requirements at high efficiency for the vehicle test cycles. Careful laboratory testing of the vehicle systems is being performed in the laboratory using a Bitrode battery tester, which controls the discharge of the ultracapacitors and the lead-acid battery and provides for their appropriate charge as specified in the control strategy for the system.

The Honda Insight has been equipped with a modified on-board diagnostics (OBD) readout unit which plugs into the standard OBD port in the vehicle. The readout displays conventional engine and electric driveline component data. A MIMA (Manual Integrated Motor Assist) kit, which has been installed in the Insight, permits the driver to modify and control manually the operation of the hybrid powertrain via a manual joy stick. A circuit board, which will replace the joystick with a programmed digital signal, is being developed.

The operation of the Honda Insight has been simulated using the Advisor program, which has been modified at UC Davis to treat various hybrid drivelines including the micro-HEV and the mild hybrid cases. The simulation results indicate that the fuel economy of the micro-hybrid can be significantly higher than the conventional ICE vehicle, but significantly lower than that of a mild-hybrid using a higher power electric motor and a more extensive energy storage unit (battery or ultracapacitor). The simulations indicate that the fuel

economies of the mild-hybrid using the NMH battery or the ultracapacitors are not expected to be much different.

Keyword: hybrid electric vehicle, micro-hybrid, mild-hybrid, ultracapacitor, control

1. Introduction

This paper is concerned with the application of ultracapacitors (electrochemical capacitors) in hybrid electric vehicles. These applications of ultracapacitors have been of great interest to the developers of the devices for almost twenty years, but the auto industry has been hesitant to even seriously consider their use until recently for start-stop hybrid vehicles. Simulations of hybrid vehicles have shown the advantages of using ultracapacitors alone or in combination with batteries, but except for transit buses, there have been relatively few passenger vehicle demonstrations of hybrid-electric powertrains incorporating ultracapacitors.

This paper describes work directed toward the demonstration of ultracapacitors in a 2001 Honda Insight. The Insight as designed by Honda is a single-shaft, parallel, mild hybrid with a 144V nickel metal hydride (NMH) battery and a 10 kW electric motor/generator. The engine turns off and on only when the vehicle is stopped. The engine and electric motor are integrated on the same shaft and there is no clutch to decouple the engine from the drive shaft. The engine is started in a small fraction of a second using the 10 kW motor. The Insight has no alternator and the 12V accessory lead-acid battery is charged off the NMH battery via a DC/DC converter. The powertrain control strategy is basically a power assist strategy in which the electric motor is used to provide additional torque to the 50 kW engine during hard accelerations and to recover energy during braking. The electric motor operating as a generator is also used to maintain the NMH battery in a narrow range of state-of-charge to achieve long cycle life.

The general approach used in this project is to replace the NMH battery with ultracapacitor modules maintaining the 12V lead-acid battery to power the accessories. Both the ultracapacitors and the 12V battery will be recharged from the

electric motor/generator driven by the engine. The Insight will be modified so that it can operate as a stop-start hybrid with and without power assist and as a mild hybrid using the full power capability of its 10 kW electric motor. In the case of the start-stop hybrid, the modified Insight will use 16V ultracapacitor modules; in the case of the mild hybrid, the vehicle will use 48V modules as part of a 176V electric driveline. The ultracapacitors used in the project were provided by NessCap. The characteristics of the energy storage units used in the start-stop and mild hybrid electric drivelines are summarized in Table 1.

2. Vehicle applications of ultracapacitors

For nearly all the hybrid vehicles on the market, batteries have been the technology of choice for energy storage. Hence essentially all testing of ultracapacitors in vehicles has been done as part of research projects [1,2]. The primary exceptions [3, 4] have been in a few hundred transit buses which have been marketed in the United States, Japan, and China. This paper is concerned with the use of ultracapacitors in light-duty vehicles, primarily passenger cars. Hence several of light-duty projects will be discussed briefly in this section.

The project most closely related to the present project is that discussed in [2] which involved the replacement of the nickel metal hydride battery pack in a hybrid (belt alternator starter) Saturn Vue with ultracapacitors. The electric driveline in the Vue was 48V. The ultracapacitors used in the project were 48V, 165F modules from Maxwell. The nickel metal hydride battery was replaced by one or two of the 48V modules which each stored about 40 Wh. There was no change in the electronics or control strategy of the vehicle and the Vue was tested using the nickel metal hydride battery and the ultracapacitors interchangeably. It was found from chassis dynamometer tests that the fuel economy of the Vue was the same using either of the energy storage units for both the FUDS and

Table 1: Characteristics of the various energy storage units to be used in the Insight

Configuration	Capacitance F	Resistance mOhm	Useable energy Wh (V ₀ to V ₀ /2)	Max.Power 95% eff. kW *	Module Weight kg
3000F cell	3203	.42	2.35	.49	.52
16V module	528	2.52	13.1	2.84	6.0
2P 16V module	1041	1.28	26.2	5.6	12.0
48V module	169	7.3	38.6	8.84	15.0
3S 48V module	56	21.9	117	26.5	45.0

*calculated from $P = 9/16 (1 - EF) V_0^2 / R$

US06 driving cycles. The energy use from the ultracapacitors was only 25-30 Wh for the FUDS cycle and less than 20 Wh for the US 06 cycle. The tests indicated a fuel consumption reduction of about 22% by hybridizing the Vue with either the battery or ultracapacitors. The energy storage of one 48V module was sufficient and the second module was not needed to meet its energy storage requirement of the vehicle on either the FUDS or US06 cycle.

Another study closely related to the present project is described in [5]. This work was done by CAP-XX, an ultracapacitor developer from Australia. Until rather recently, CAP-XX marketed small devices for the consumer electronics market [6]. They have recently announced [5] they have developed large devices (1400F) for vehicle markets. CAP-XX identified the stop-start hybrid market as a primary application they have targeted. In [5], they indicated they have been testing a 14V, 165F module with a lead-acid battery in a start-stop hybrid to start the engine and recovery braking energy. The testing has been successful and has indicated that the cycle life of the lead-acid battery is much greater with the ultracapacitor present. As indicated in the testing of the Saturn Vue, storage of only a small amount of energy in the ultracapacitors is needed compared to what would be stored in a battery in the same application.

3. Laboratory tests of cells and modules

The first phase of the present study involved testing of the ultracapacitors to be used in the 2001 Insight. As noted previously, NessCap provided 16V and 48V modules (Figures 1) consisting of 3000F cells connected in series. Each of the

modules was provided with fan-air cooling and circuits to monitor the voltage and temperatures of the cells. Test data for the 3000F cells are given in Table 2. Test data for the modules are given in Table 3. The characteristics of the modules were found to follow closely that expected based on the cell characteristics. The maximum power capability (95% efficiency) of each of the energy storage units is shown in Table 1.



16V module (6 x 3000F cells)

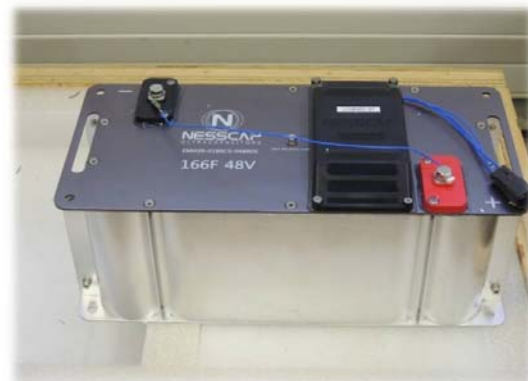

48V module (18 x 3000F cells)

Figure 1: NessCap 16V and 48V modules

Table 2: Characteristics of the NessCap 3000F cell



Test configuration	Capacitance F	Resistance R (mOhm)	Wh	Weight kg (cells)	Wh/kg
Single cell					
200A	3203	.42			
300W			2.3	.52	4.4
16V module					
200A	528	2.52			
1.8 kW			13.1	3.12	4.2
16V module (2P)					
400A	1041	1.28			
3.2 kW			26.2	6.24	4.2
48V module					
200A	169				
5.4 kW		7.3	38.6	9.36	4.1
48V module (3P)					
400A	514	2.5			
9.5 kW			117	28.1	4.2

Table 3: Test results for the Nesscap modules

Test configuration	Capacitance F	Resistance R (mOhm)	Wh	Weight kg (cells)	Wh/kg
Single cell					
200A	3203	.42			
300W			2.3	.52	4.4
16V module					
200A	528	2.52			
1.8 kW			13.1	3.12	4.2
16V module (2P)					
400A	1041	1.28			
3.2 kW			26.2	6.24	4.2
48V module					
200A	169				
5.4 kW		7.3	38.6	9.36	4.1
48V module (3P)					
400A	514	2.5			
9.5 kW			117	28.1	4.2

The energy storage units were also tested in the laboratory using cycles appropriate for the vehicle tests. These cycles are listed in Table 4. Each of the cycles includes providing power for the accessory loads, starting the engine, and power assist and recharge off the engine and during regenerative braking. As shown in Table 1, the

maximum power capability of each of the storage units is sufficient to meet the power requirements at high efficiency for the test cycles. The cycle tests for the 16V and 48V modules are shown in Figure 2. The data indicate that the energy storage units will meet the requirements of the vehicle tests planned.

Table 4: Test cycles used to simulate operation of the storage units in the Insight

<u>16V stop-start</u>		
Accessory load	1200W x 30sec	10 Wh
Engine start	3000W x 1 sec	1 Wh
Recharge module	2000W for up to 15 sec (14V max)	12.5 Wh (charge)
Regen braking	2000W x 4 sec (16V max)	2.2 Wh (charge)
<u>2P 16V stop-start with power assist</u>		
Accessory load	1200W x 30sec	10 Wh
Engine start	3000W x 1 sec	1 Wh
Power assist	3000W x 8sec	7 Wh
Recharge module	3000W for up to 22 sec (14V max)	22 Wh (charge)
Regen braking	3000W x 4 sec (16V max)	3.3 Wh (charge)
<u>3P 48V modules for mild--hybrids</u>		
Accessory load	1200W x 60sec	20 Wh
Engine start	4000W x 1 sec	1 Wh
Power assist	9500W x 20sec	52 Wh
Recharge module	9500W for up to 30 sec (42V max)	80 Wh (charge)
Regen braking	9500W x 5 sec (48V max)	13 Wh (charge)

4. Vehicle installation of the ultracapacitors

The Insight is a two-seat vehicle with much space behind the front seats. The nickel metal hydride (NMH) battery, DC/DC converter, and other electronics are mounted under the rear platform. There is also a storage compartment that contains the spare tire and room for storing other items. The size of this compartment with the spare tire removed is 24" x 24" x 24", which is large enough for placement of the ultracapacitors even three of the 48V modules (see Figure 3). At least for initial testing the ultracapacitors will be connected in parallel with the NMH battery with the ability to switch back-and-forth from one energy storage unit to the other.

The schematics of the electric driveline system for the micro- and mild-hybrid arrangements are shown in Figure 4. The system (4b) for the mild-hybrid is relatively simple because the

ultracapacitors will replace the NMH battery. The system will have a nominal voltage of about 170V and function nearly the same as in the original Insight. The system (3a) for the micro-hybrid will be much different than in the original Insight. It will have an operating voltage of 12-16V with the ultracapacitors in parallel with the 12V lead-acid battery. Since the Insight does not have an alternator, both the lead-acid battery and ultracapacitors will be recharged using the DC/DC converter with current from the motor/generator powered by the engine. As indicated in Figure 4a, whether the 12V battery or the ultracapacitor is being recharged depends on the setting of switches SW₁ and SW₂. The engine will be started using the ultracapacitors except when their voltage is too low. In that case, the engine will be started by the 12V battery. This should occur very infrequently. Complete descriptions of the control strategies for the hybrid operations of the Insight are given in Section 6 of the paper.

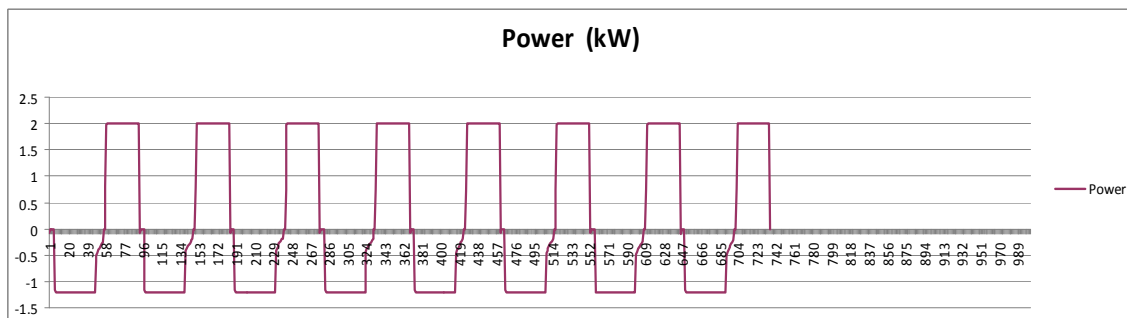
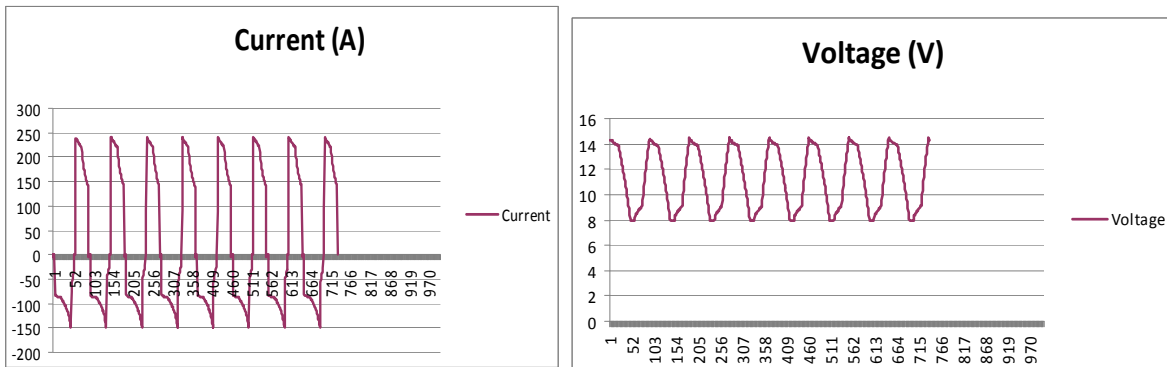

16V module cycling to simulate a micro-start-stop HEV (9.5 Wh out)

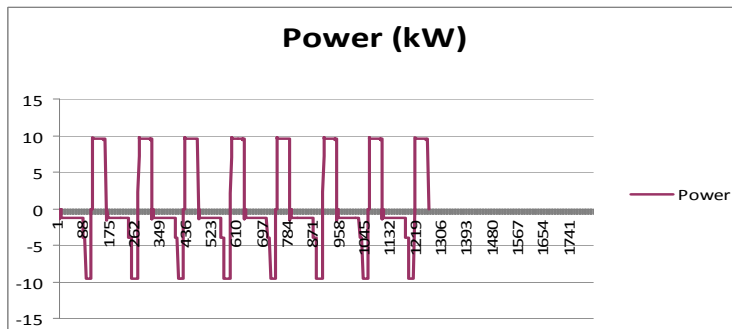
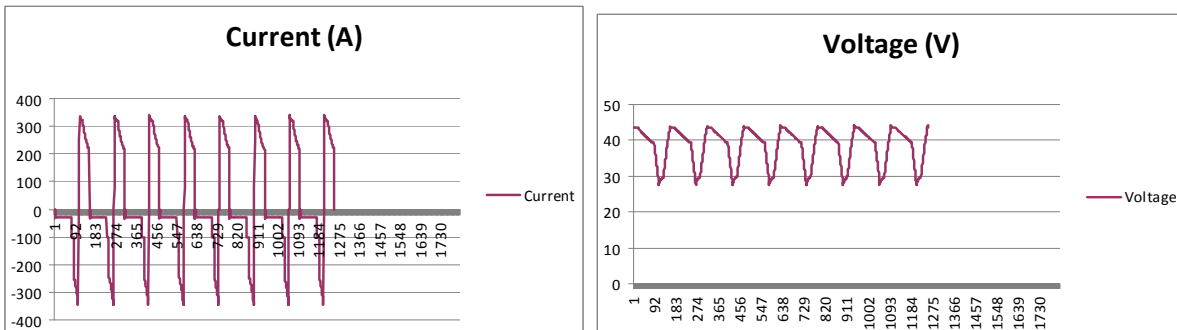

48V module cycling to simulate a cap-alone HEV (73 Wh out)

Figure 2: Cycle tests of the energy storage units



Figure 3: Rear section of the Insight showing the electronics and ultracapacitors in the storage compartment

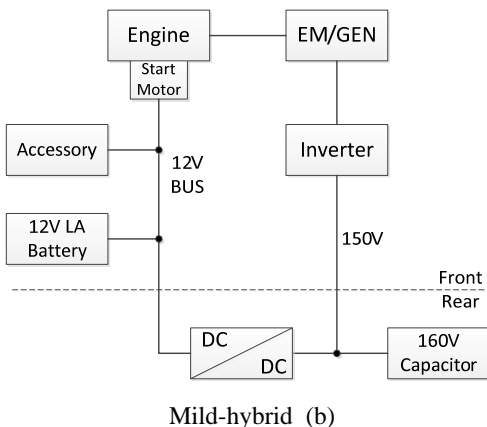
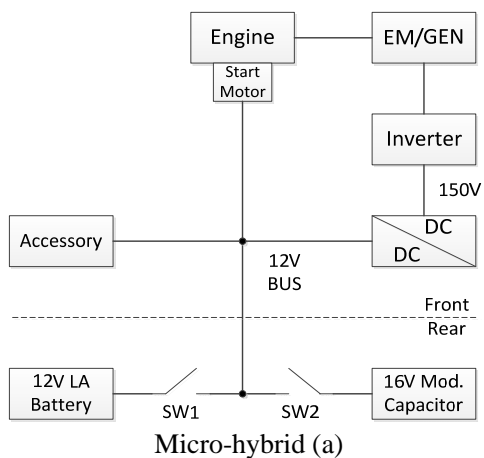

Figure 4: Schematics of the electric drive systems with the ultracapacitors

5. Vehicle instrumentation and data logging

The Honda Insight has been equipped with a modified on-board diagnostics (OBD) readout unit which plugs into the standard OBD port in the vehicle. The readout unit was developed through collaboration by members of an “Online Hybrid Vehicle Forum” in order to provide features useful to hybrid vehicle owners and research scientists. The readout displays conventional engine data from commercially available OBD scanners and the following parameters unique to hybrid vehicles:

- Battery state of charge.
- Electric motor torque, temperature, rpm, and power consumption.
- Engine lean burn operation.
- Auxiliary load and battery charging.

The OBD readout samples 8 parameters simultaneously at up to 19,200 Baud. Different combinations of operation parameters can be selected. A useful tool of the OBD readout is the recognition, alert, and ability to toggle on-and-off various fault codes in the vehicle’s control modules. This allows for avoidance and protection of sensitive electronics while approaching an accurate, real-world level of maximum powertrain performance. The OBD readout samples temperature values in many locations on the

vehicle; additional outputs are tied into 10k thermistors attached to battery and later to the ultracapacitor assemblies.

To supplement and verify the speed, distance, acceleration, and energy usage values generated from the OBD readings, an additional system is installed in the vehicle which uses a current shunt and GPS (Global Positioning Satellite). The unit is called the Cycle Analyst, and like the OBD readout, it was developed by do-it-yourself electric vehicle enthusiasts. The GPS data will verify drive cycle distance and conditions including:

- Outside temperature
- Elevation change
- Acceleration rates
- Speed
- Distance
- Time

Accurately measuring the electric motor power and energy used both into and out of the battery will be improved by using calibrated aftermarket shunts installed between the battery or ultra-capacitor and the Cycle Analyst unit. This system will also be used in testing 12 volt system operation. The OBD readout and laptop running PLX-DAQ Data Acquisition Software logging data during a vehicle drive are shown in Figure 5.



Figure 5: OBD readout (left) and laptop running PLX-DAQ Data Acquisition Software (right) logging data during a vehicle drive.

The instrumentation outlined in the previous paragraphs supports the reading, verification, and logging of data during testing. The MIMA (Manual Integrated Motor Assist) kit installed in the vehicle, shown in Figure 6, adds the ability to modify and control manually the operation of the hybrid

powertrain in the Insight. The MIMA kit was developed specifically for the first generation (2001) Honda Insight, allowing a variety of control parameters to be modified and controlled during vehicle testing. A manual joystick located near the gear selector permits the driver to have full control of power assist, regenerative braking, and supplementary charge.

A circuit board which replaces the standard manual joystick signal with a programmed digital signal to recreate operating modes of the test vehicle is being developed. This circuit board will be used during testing of the Insight when automatic control of the 12-16 volt system in the micro-hybrid and the 170V system in the mild hybrid with ultracapacitors are demonstrated and evaluated for comparison with the Insight using the nickel metal hydride battery.

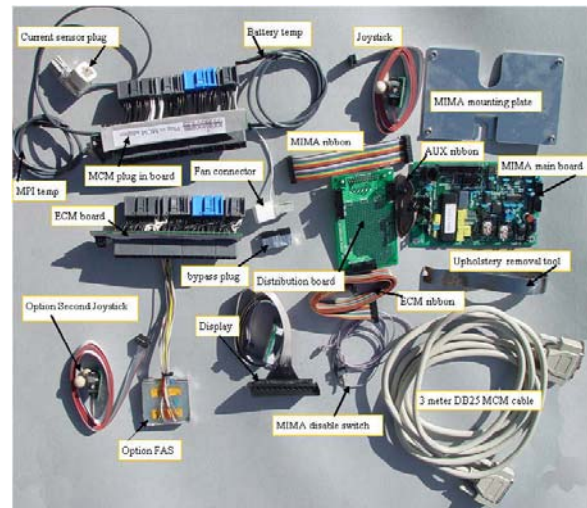

Figure 6: The Manual Integrated Motor Assist kit
Source: 99MPG.COM

6. Control strategies for maximum efficiency

The control strategies for the micro- and mild-hybrid operation of the Insight will be discussed separately. The intent of both strategies is to maximize the efficiency of the driveline and hence maximize the fuel economy of the vehicle.

Micro-hybrid (12-16V) operation

As indicated in Figure 4a, the micro-hybrid energy storage will operate at a voltage of 12-16V. Both the ultracapacitors and the lead-acid battery will be

recharged from the 150V motor/generator on the engine shaft using the DC/DC converter. As indicated in Section 3, the ultracapacitors can provide the power to start the engine and the energy for the accessories when the engine is off. However, the energy available from the ultracapacitors is limited and hence on some occasions, the lead-acid battery will be needed to start the engine and power the accessories. It is expected this will be sufficiently infrequent that the life of the lead-acid battery will not be significantly impacted. The currents required can be relatively high (100-200A), but only in pulses for less than 30 sec in most instances. Testing of the lead-acid battery (about 30 Ah capacity) from the Insight will be performed to validate that it will be able to meet the power and energy demands of the micro-hybrid control strategy. Otherwise it will be replaced by a larger Ah capacity battery. In the original Insight, the air-conditioning (AC) system is driven off the engine and this will continue in the UCD modified Insight which means that the engine will not turn-off if the AC is running. This also occurs in the original Insight although there is an "Economy" mode for the AC that does permit the engine to turn-off. It is expected that this feature will be maintained in the modified Insight.

The key features of the micro-hybrid control strategy are that the engine will be turned off when the vehicle is at rest, energy will be recovered during regenerative braking, and the ultracapacitors and the lead-acid battery will be recharged by the engine via motor/generator, which acts as the alternator in the system. The power from the 10 kW motor/generator will be limited to 3 kW in the micro-hybrid stop-start Insight. The engine will be restarted using the 16V ultracapacitor module and it will provide the accessory power when the engine is off. When the engine is on (being fueled), it will power the vehicle and in addition, recharge the ultracapacitors and when needed, the lead-acid battery. The high efficiency of the ultracapacitors will minimize the losses associated with their recharging. As discussed in Section 5, the operation of the vehicle in terms of engine on-off and battery recharging can be controlled using a joy-stick. For driving the Insight as a micro-hybrid, this manual joy-stick operation will be replaced by a programmable controller which makes use of the input signal circuit board of the

joy-stick. The intent is to make driving the modified Insight as convenient for the driver as the original Insight.

The original Insight is essentially a power-assist hybrid in which the improvement in fuel economy is due to down-sizing the engine, recovering energy from regenerative braking, and reducing the weight and aerodynamic drag of the vehicle. There seems to be little attention given to improving the efficiency of the engine operation by utilizing the electric drive when the power demand would result in low efficiency operation of the engine. This, of course, would require the fueling of the engine to be turned off- on while the vehicle is in motion. This could be done with the Insight if the DC/DC converter was bi-directional so that the ultracapacitors could be used to power the 155V electric motor. This arrangement would permit the operation of the Insight as a power-assist micro-hybrid. It is likely in this arrangement more energy storage would be needed. This can be accomplished using two of the 16V modules in parallel (see Table 1). The control strategy in this mode of operation would be similar to that previously described except that torque/power from the electric motor would be added during vehicle accelerations (Table 4).

Mild hybrid (170V) operation

The driveline and energy storage for the mild hybrid operation of the Insight is shown schematically in Figure 4b. In this case, the NMH battery will be replaced by the ultracapacitor unit, but the system will be operated in much the same way as it would using the NMD battery. The system voltage will be increased from 144V to 176V by combining three 48V modules and two 16V modules so that the operating voltage range of the energy storage system will be from 176V to 120V, which will permit the use of 53.5% of the energy stored in the ultracapacitors (76.5 Wh). The maximum currents (DC) will be about 125A. The engine will be started at rest using the 10 kW electric motor on the engine shaft with electrical energy from the ultracapacitors. Even though the engine cannot be decoupled from the drive shaft, tests will be performed to determine if fueling the engine can be interrupted and restarted when the vehicle is in motion and engine power is not needed for high efficiency system operation. Charging the ultracapacitors at high rates is very

efficient so on/off engine operation when the vehicle is in motion will maximize vehicle fuel economy (see Section 8).

7. Laboratory testing with the micro-hybrid arrangement

Before installing the ultracapacitors and associated components in the Insight, careful laboratory testing of the systems is being performed in the laboratory. The test setup for the micro-hybrid (start-stop) system is shown in Figure 7. This setup is tested using a Bitrode battery tester, which controls the discharge of the ultracapacitors and the lead-acid battery and provides for their appropriate charge as specified in the control strategy for the system.



Figure 7: Laboratory test set-up for the micro-hybrid arrangement

As shown in Figure 7, whether the ultracapacitor or the lead-acid battery branch of the circuit is active is controlled by the two switches (Tyco

Electronics, kilovac relay) which are activated by solenoid coils (12V). Testing of the switches indicate they open and close in 50-60 ms with opening somewhat faster than closing. There can be short periods in which both switches are open or closed, but those periods are relatively short (10-20 ms at most). Preliminary testing has shown that the circuit (Figure 7) operates satisfactory for sequential cycling like that given in Table 5.

The total time for the 9 sub cycles is about 600 sec. The cycle will be repeated at least 10 times. During that time, the lead-acid battery should need charging several times.

Rules for control of ultracaps and lead-acid battery

Ultracaps (SW1 closed, SW2 open)

Discharge of ultracaps **start** if $V_{cap} > 11V$ and **stop** when $V_{cap} = 9V$
 Recharge caps to 14.5V (20 sec or less of recharge)
 Regenerative braking charge to 16V max

Lead-acid battery (assume 30Ah capacity) (SW2 closed, SW1 open)

Use battery for discharge if caps cannot be discharged
 Recharge battery if $V_{cap} > 14.5V$ and $(Ah)_{net}$ of the battery is between 6 and 9.
 Regenerative braking energy always into ultracaps

Table 5: Test procedures for the micro-hybrid system testing

Steps Cycle no.	Accessories		Engine start (1)		Recharge (2)		Regen. braking (3)	
	W	sec	W	sec	W	sec	W	sec
1	800	30	3000	1	2000	20	2000	4
2	800	30	3000	1	2000	20	2000	6
3	800	90	3000	1	2000	20	2000	2
4	800	15	3000	1	2000	20	2000	8
5	800	60	3000	1	2000	20	2000	6
6	800	30	3000	1	2000	20	2000	4
7	800	60	3000	1	2000	20	2000	4
8	800	15	3000	1	2000	20	2000	2
9	800	30	3000	1	2000	20	2000	6

(1) All engine start steps the same 1 sec

(2) Recharge should take caps to 14.5V with a max charging time of 20 sec

(3) Regenerative braking step should result in caps to at least 15.5V

Table 6: Summary of Advisor results for the 2001 Honda Insight

Vehicle configuration *	mpg FUDS cycle	mpg Highway cycle
Conventional ICE	41.7	56
Insight		
NREL default	55	75.2
Micro-HEV		
Caps-LA bat, 4 kw EM	59.7	75.9
Caps-LA bat, 1 kw EM	53.8	73
Mild-HEV		
NMH bat, 10 kW EM	77	83.6
Ultracaps, 10 kW EM	77.7	83.9

*Insight $C_D=0.25$, $A_F=1.9m^2$, $W=1036$ kg, CVT, 50 kW 3 cyl. engine

8. Advisor simulation results

The 2001 Honda Insight was simulated for a number of driveline configurations using the Advisor vehicle simulation computer program. As discussed in [7-9], Advisor has been modified at UC Davis to treat various hybrid drivelines including the micro-HEV and the mild hybrid cases. All the hybrid vehicle simulations included regenerative braking and on/off engine operation with the engine attached and on the same shaft as the electric motor. The results of the simulations are summarized in Table 6. All the simulations used the same test weight, road load parameters, CVT transmission, and engine and electric motor characteristics.

The simulation results indicate that the fuel economy of the micro-hybrid can be significantly higher than the conventional ICE vehicle, but significantly lower than that of a mild-hybrid using a higher power electric motor and a more extensive energy storage unit (battery or ultracapacitor). The simulations indicate that the fuel economy of the mild-hybrid using the NMH battery or the ultracapacitors is not expected to be much different. These simulation results will be compared with the vehicle test results when the hybrid vehicle assembly using the ultracapacitors is completed.

Detailed simulation results showing the discharge/charge characteristics of the lead-acid battery and ultracapacitor in the micro-hybrid on the FUDS cycle are given in Figure 8 and for the ultracapacitor in the mild- hybrid in Figures 9. In both cases, the ultracapacitors are used over a wide

range of power and state-of-charge and function at high efficiency (>98%). These simulation results

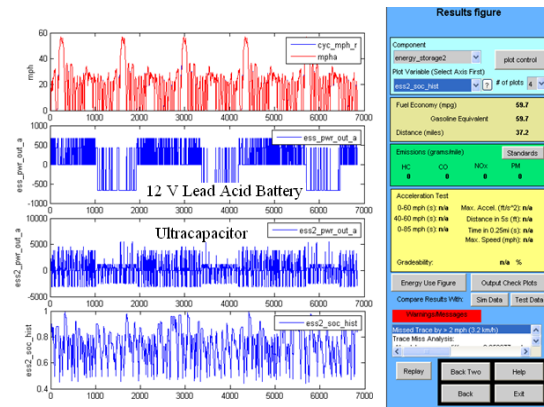

Figure 8: Simulation of the operation of the lead-acid battery and ultracapacitors in the micro-hybrid Insight on the FUDS driving cycle

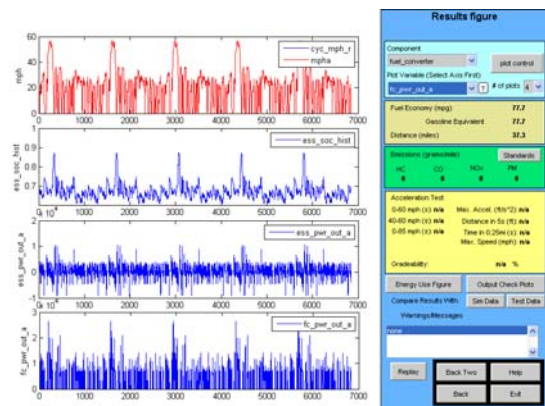

Figure 9: Simulation of the operation of the ultracapacitors in the mild-hybrid Insight on the FUDS driving cycle

indicate that the ultracapacitor units that will be used in the Insight vehicle tests (see Figure 1 and Table 3) should function as projected in both the micro-hybrid and the mild-hybrid drivelines.

9. Summary and conclusions

This paper describes work directed toward the demonstration of ultracapacitors in a 2001 Honda Insight. The Insight as designed by Honda is a single-shaft, parallel, mild hybrid with a 144V nickel metal hydride (NMH) battery and a 10 kW electric motor/generator. The engine turns off and on only when the vehicle is stopped. The engine and electric motor are integrated on the same shaft and there is no clutch to decouple the engine from the drive shaft. The general approach used in this project is to replace the NMH battery with ultracapacitor modules maintaining the 12V lead-acid battery to power the accessories. Both the ultracapacitors and the 12V battery will be recharged from the electric motor/generator driven by the engine. The Insight will be modified so that it can operate as a start-stop hybrid with and without power assist and as a mild hybrid using the full power capability of its 10 kW electric motor. In the case of the start-stop hybrid, the modified Insight will use 16V ultracapacitor modules; in the case of the mild hybrid, the vehicle will use 48V modules as part of a 176V electric driveline. The ultracapacitors used in the project were provided by NessCap.

The first phase of the project involved testing of the ultracapacitors to be used in the Insight. The energy storage units were tested in the laboratory using cycles appropriate for the vehicle tests. Each of the cycles includes providing power for the accessory loads, starting the engine, and power assist and recharge off the engine and during regenerative braking. The maximum power capability of each of the storage units was found to be sufficient to meet the power requirements at high efficiency for the test cycles. Before installing the ultracapacitors and associated components in the Insight, careful laboratory testing of the vehicle systems is being performed in the laboratory. The lab setup is being tested using a Bitrode battery tester, which controls the discharge of the ultracapacitors and the lead-acid

battery and provides for their appropriate charge as specified in the control strategy for the system.

The Honda Insight has been equipped with a modified on-board diagnostics (OBD) readout unit which plugs into the standard OBD port in the vehicle. The readout unit was developed through collaboration by members of an "Online Hybrid Vehicle Forum" in order to provide features useful to hybrid vehicle owners and research scientists. The readout displays conventional engine data from commercially available OBD scanners and the following parameters unique to hybrid vehicles:

- Battery state of charge.
- Electric motor torque, temperature, rpm, and power consumption.
- Engine lean burn operation.
- Auxiliary load and battery charging.

A MIMA (Manual Integrated Motor Assist) kit, which has been installed in the Insight, permits the driver to modify and control manually the operation of the hybrid powertrain. The MIMA kit was developed specifically for the first generation (2001) Honda Insight, allowing a variety of control parameters to be modified and controlled during vehicle testing. A manual joystick located near the gear selector permits the driver to have full control of power assist, regenerative braking, and supplementary charge. A circuit board, which will replace the standard manual joystick with a programmed digital signal to recreate operating modes of the test vehicle, is being developed.

The operation of the 2001 Honda Insight was simulated for a number of driveline configurations using the Advisor vehicle simulation computer program. Advisor has been modified at UC Davis to treat various hybrid drivelines including the micro-HEV and the mild hybrid cases. All the hybrid vehicle simulations included regenerative braking and on/off engine operation with the engine attached and on the same shaft as the electric motor and used the same test weight, road load parameters, CVT transmission, and engine and electric motor characteristics. The simulation results indicate that the fuel economy of the micro-hybrid can be significantly higher than the

conventional ICE vehicle, but significantly lower than that of a mild-hybrid using a higher power electric motor and a more extensive energy storage unit (battery or ultracapacitor). The simulations indicate that the fuel economy of the mild-hybrid using the NMH battery or the ultracapacitors is not expected to be much different. These simulation results will be compared with the vehicle test results when the hybrid vehicle assembly using the ultracapacitors is completed.

References

- [1] Schwake, A., EC-funded Project “SUPERCAR”: Ultracapacitor Modules for Mild Hybrid Applications, Proceedings of the Second International Symposium on Large Ultracapacitor (EDLC) Technology and Application, Baltimore, Maryland, May 16-17, 2006
- [2] Gonder, J., Pesaran, A., Lustbader, J., and Tatara, H., Hybrid Vehicle Comparison Testing Using Ultracapacitor vs. Battery Energy Storage, SAE 2010 Hybrid Vehicle Technologies Symposium, San Diego, California, February 10-11, 2010
- [3] Bartley, T., Ultracapacitor Energy Storage in Heavy-duty Hybrid Drive Update, Proceedings of the Advanced Capacitor World Summit 2005, San Diego, California, July 2005
- [4] King, R.D., and etals., Performance and Emissions Test Results of a Low-floor, Low-emissions Transit Bus with a 225 kW Hybrid – Electric Propulsion System, EVS-21, Monaco, April 2005
- [5] Buckle, P., Supercapacitors in Micro-hybrid Vehicles, presentation by CAP-XX at the Advanced Automotive Battery Conference in Strasbourg, June 24-28, 2013
- [6] Web page of CAP-XX, www.cap-xx.com
- [7] Burke, A.F., Zhao, H., and Van Gelder, E., Simulated Performance of Alternative Hybrid-Electric Powertrains in Vehicles on Various Driving Cycles, EVS-24, Stavanger, Norway, May 2009 (paper on the CD of the meeting)
- [8] Burke, A.F., Application of Ultracapacitors in Mild/Moderate Hybrid-electric Vehicles, paper

presented at the ESScap06, Switzerland, November 2006

- [9] Burke, A.F. and Van Gelder, E., Plug-in Hybrid-Electric Vehicle Powertrain Design and Control Strategy Options and Simulation Results with Lithium-ion Batteries, paper presented at EET-2008 European Ele-Drive Conference, Geneva, Switzerland, March 12, 2008 (paper on CD of proceedings)

Authors



Andrew Burke, Research faculty
ITS-Davis, University of California –
Davis, 1605 Tilia Street., Davis, CA
95616, USA.

Tel.: +1 (530) 752-9812

Email: afb Burke@ucdavis.edu

Ph.D., 1967, Princeton University. Since 1974, Dr. Burke’s research has involved many aspects of electric and hybrid vehicle design, analysis, and testing. He was a key contributor on the US Department of Energy Hybrid Test Vehicles (HTV) project while working at the General Electric Research and Development Center. He continued his work on electric vehicle technology, while Professor of Mechanical Engineering at Union College and later as a research manager with the Idaho National Engineering Laboratory (INEL). Dr. Burke joined the research faculty of the ITS-Davis in 1994. He directs the EV Power Systems Laboratory and performs research and teaches graduate courses on advanced electric driveline technologies, specializing in batteries, ultracapacitors, fuel cells and hybrid vehicle design. Dr. Burke has authored over 80 publications on electric and hybrid vehicle technology and applications of batteries and ultracapacitors for electric vehicles.



Marshall Miller, Senior Development
Engineer

ITS-Davis, University of California -
Davis. One Shields Ave., Davis, CA
95616, USA.

Tel.: +1 (530) 752-1543

Email: mmiller@ucdavis.edu

He is the Director of the Hydrogen Bus Technology Validation Program which studies fuel cell and hydrogen enriched natural gas buses. He also supervises testing in the Hybrid Vehicle Propulsion Systems Laboratory where he does research on fuel cells, advanced batteries, and ultracapacitor technology. His overall research has focused on advanced environmental vehicles and fueling infrastructure to reduce emissions, greenhouse gases, and oil usage. He received his B.S. in Engineering

Science and his M.S. in Nuclear Engineering from the University of Michigan. He received his Ph.D. in Physics from the University of Pennsylvania in 1988.



Hengbing Zhao, Research Engineer
ITS-Davis, University of California –
Davis, 1605 Tilia Street., Davis, CA
95616, USA

Tel.: +1 (530) 754-9000

Email: hbzhao@ucdavis.edu

He received his Ph.D. at Zhejiang University in 1999. His research has involved many aspects of battery electric vehicles, fuel cell vehicles, hybrid electric vehicles, distributed power generation systems, and intelligent electric vehicle charging stations. His particular interests are vehicle hybridization and applications of batteries and ultracapacitors for electric vehicles.



Michael Radenbaugh, He received his bachelor degree in Industrial Technology from California State University Humboldt. He is currently a second-year Master's candidate in Transportation Technology and Policy in ITS-Davis. He is working on electric

and hybrid vehicle technology and market evaluation.



Zhengmao Liu, Master's Candidate
ITS-Davis, University of California -
Davis, 1605 Tilia Street, Davis, CA
95616, USA

Tel: +1 (530) 750-9259

Email : zhmliu@ucdavis.edu

He received his bachelor degree in vehicle engineering in South China University of Technology, China. He is currently a master candidate in mechanical engineering and Transportation Technology and Policy at ITS-UC Davis. He is working on hybrid vehicle fuel efficiency and electric vehicle driveline optimization. His research also includes hybrid vehicle dynamics analysis, vehicle electronics, and vehicle test and measurement.