

Electric Traction System for a Supercapacitor-Based Electric Vehicle

Edgar Peralta-Sanchez¹, Jaime José Rodríguez-Rivas²

¹Universidad Popular Autónoma del Estado de Puebla (UPAEP), México, edgar.peralta@upaep.mx

²Instituto Politécnico Nacional, México City, jjrodriguez@ipn.mx

Abstract

This work addresses the design of the electric traction system of an Electric Vehicle (EV) which uses supercapacitors as the only energy source. The aim of this work is to build a small EV prototype to research about the feasibility of using supercapacitor based EVs in the public transport of Mexico City. This project is sponsored by the Institute of Science and Technology of Mexico City. The vehicle uses rear traction based on a Permanent Magnet Synchronous Motor (PMSM). A small size battery was used to power ancillary vehicle devices such as lights, instrument cluster and contactors of the energy distribution system. Simulation and experimental results are presented to validate the design of the traction system.

Keywords: permanent magnet synchronous motor, super capacitors, electric vehicle.

1 Introduction

The electric traction system of the EV is based on a 3.83 kW, 220/240 V, 12.2 N-m PMSM. The motor is driven by a 300 V POWEREX inverter. The DC voltage is provided by a bidirectional two-phase interleaved DC/DC converter which steps up the voltage provided by the supercapacitors (SCs) which are the only energy source, and steps down the motor regenerated-voltage during the braking stage. An external SC charger was designed and implemented. The SCs are recharged in 5 minutes time providing to the vehicle the autonomy needed to reach the next stop where it is recharged again and so on. The energy distribution system was implemented with the protections needed.

2 Electric Traction System

Fig. 1 illustrates the electric traction system of the EV. Contactors (1) are closed and (2) opened when the SCs need to be recharged.

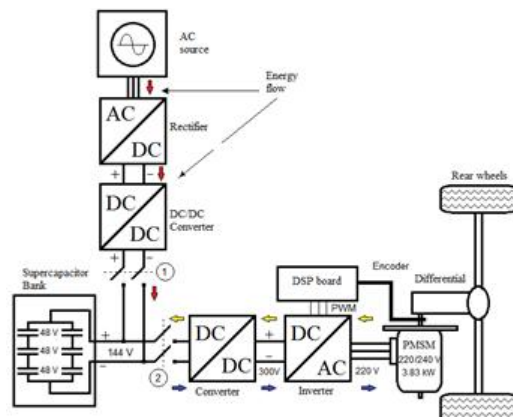

Figure 1: Electric traction system

The SC charger is comprised by the AC source, rectifier and DC/DC converter. The SCs are charged up to 144 V at constant current, the minimum SC voltage is 72 V for that voltage the SCs have delivered $\frac{3}{4}$ of their energy. Contactors (2) are closed and (1) opened during the traction stage. The DC/DC converter of the SC charger is unidirectional (step down) while the DC/DC

converter labelled with a 2 is bidirectional allowing the energy to flow from the SCs to the DC bus during the traction stage and from the DC bus to SCs during the regenerative stage. The PMSM control was programmed on a TMS320F28335 DSP system.

The control of the DC/DC converters was implemented with analog circuits. The Texas Instruments UCC 28220 integrated circuit was used to implement the PWM DC/DC converter. APT100M50J MOSFETS were used as switching devices with a commutation frequency of 40 kHz.

The bank of SCs is comprised of six Maxwell BMOD0165 (165 F, 48V) modules connected in two parallel branches of three series modules connected per branch. Fig. 2 illustrates the SC bank and fig.3 the EV.



Figure 2: Supercapacitor bank



Figure 3: Electric vehicle

3 Motor Drive

The motor drive is based on a PMSM vector control as illustrated in fig. 4. The reference speed signal is generated by the throttle. Acceleration and braking stages are controlled by the throttle, in order to increase the safety a

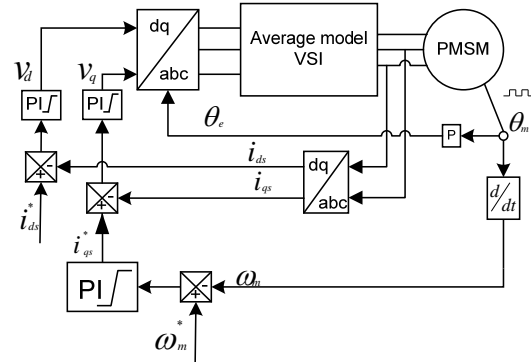

Figure 4: PMSM vector control

mechanical brake was implemented with a second pedal.

4 Dynamic Model of the EV

By analyzing the forces acting during the movement of the vehicle (see fig. 5) is possible to get the dynamic model of the EV resulting in the torque equation (1) describing the dynamic model of the EV [1]:

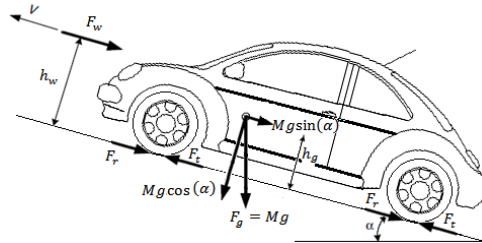

Figure 5: Forces acting on the vehicle

$$\frac{d\omega_m}{dt} = \frac{T_m - \frac{d_f r_d}{n \text{ eff}} \left(F_r + F_g + \frac{1}{2} \rho A_f C_d \frac{r_d^2}{n^2} \omega_m^2 \right)}{J_m + \frac{1}{n^2 \text{ eff}} (J_w + d_f r_d^2 M)} \quad (1)$$

where:

J_w , J_m , ω_m and r_d - are the wheel and motor rotor inertia (N.m.s), angular speed (rad/s) and mean wheel radius (m) respectively. F_r , F_g - are the total rolling resistance of the vehicle and the grading resistance (N.m) respectively. ρ , A_f , C_d and M - are the air density, vehicle frontal area, aerodynamic drag coefficient and total mass (kg) of EV respectively. n , eff , T_m and d_f - are the transmission gear ratio, transmission efficiency, traction machine torque and factor proportioning torque distribution on the rear axle respectively.

5 Simulation Results

Fig. 6 illustrates the road angles (see fig. 8a as well) of the driving cycle used for the simulations. In order to improve the time that the computer takes to simulate the system an average model of the inverter [2] and the PMSM model

reported in [3] were used. Fig. 7 illustrates the voltage and current responses of the motor for the speed profile shown in fig. 8b. Fig. 8 illustrates the vehicle performance under different reference speeds.



Figure 6: Driving cycle used for the simulation

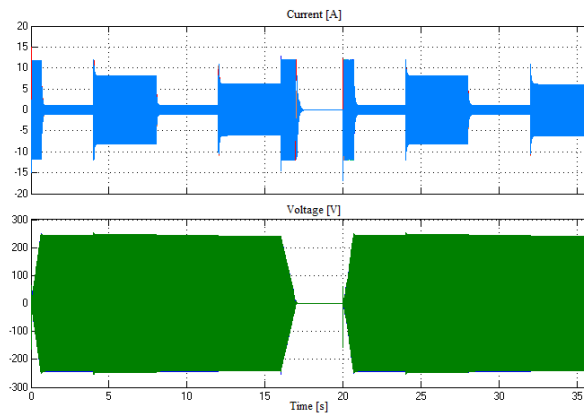

Figure 7: Instantaneous motor voltage and current values

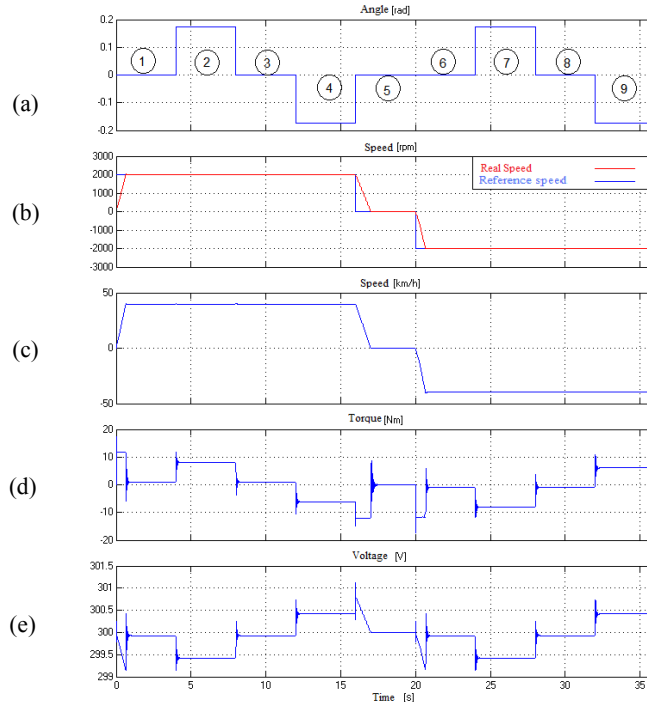

Figure 8: Simulation results of the vehicle performance

6 Experimental Results

Experimental tests were carried out by using an electrodynamicometer (ED) as illustrated in Fig. 9. The ED is comprised by two inverters (Unidrive SP3201) connected by the DC bus, these inverters are used to manage the regeneration of the load machine. The ED control was implemented on LabView, an NI USB6211 Data Acquisition Board was used as an interface between a PC and the Unidrive. The ED is able to emulate the dynamic load-profile of an EV. Another PMSM working as a traction motor was mechanically coupled to the load machine. The traction motor was driven by a Powerex

PP75T120 inverter which was fed by a TDK-Lambda GEN 300-17 power supply. Diodes connected in series with the power supply are used to block the regeneration from the traction motor to the power supply. To emulate the regenerative braking stage of an EV braking resistors are needed to dissipate the regenerated energy. Vector control algorithms were programmed on a Freescale DSCMC56F8357 for the motor control. Data of the motors are as follows: Control Techniques servomotors 7.75 kW, 26.35 A_{rms}, 36.9 Nm, 220/240 V, 2000 rpm. Fig. 10 illustrates the experimental setup as it was implemented in the lab. The ED allows testing the control algorithms of the traction motor.

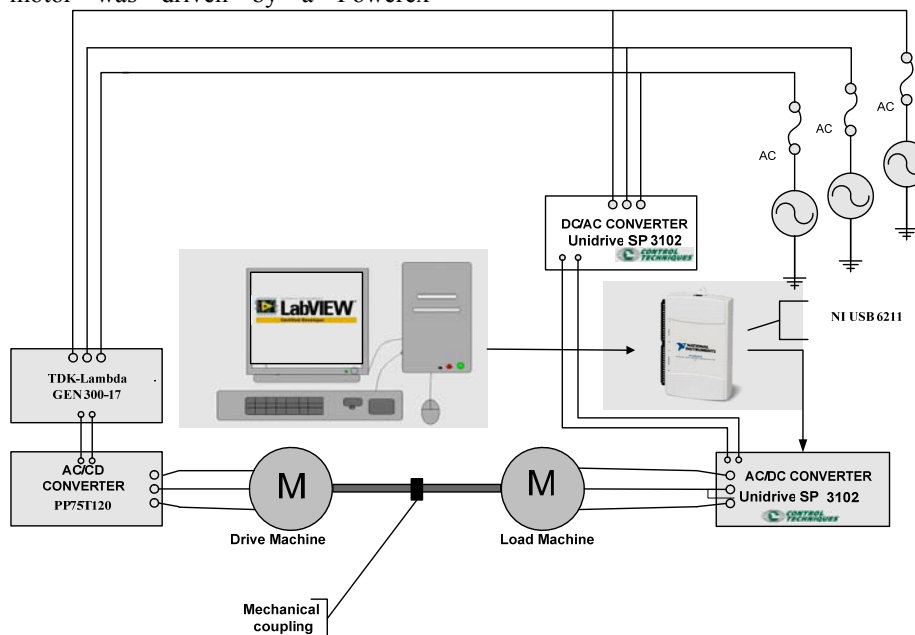

Figure 9. Block diagram of the experimental setup.

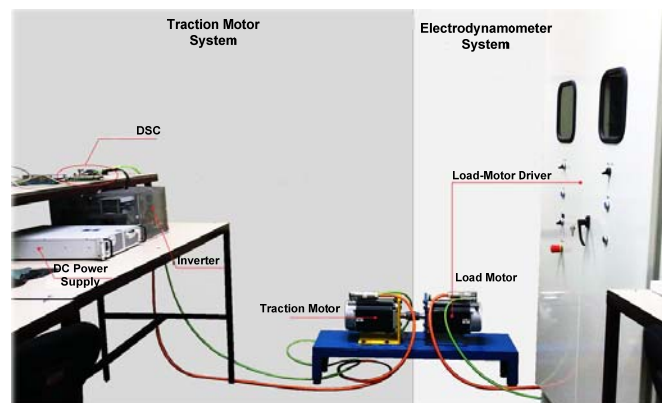

Figure 10. Experimental setup

Fig.11 shows the speed, electromagnetic torque of the motor, motor power and dc bus voltage. The EV speed profile used is shown in Fig. 11a. Variations of the traction motor torque are illustrated in Fig. 11b. This figure shows the electromagnetic torque of the traction motor T_{em} , the reference torque of the ED $T_{e^*_{el}}$, and the torque produced by the load machine $T_{e_{el}}$, all of them correlate very well suggesting that the system is working as it was expected. The torque T_{em} fluctuations of the traction motor are due to the fact that this signal is taken from a PWM output of the DSC where the traction motor control was implemented. The signal was filtered and then was acquired by a NI USB 6211 to be plotted finally by LabView along with the other torques.

Fig. 11c illustrates the power in the shaft of the traction motor, the negative values corresponds to

the regenerated power from the electrodynamicometer to the grid (electric traction) and the positive values are due to the regenerative braking of the traction motor. The increase of the voltage in the DC bus of the inverter (see Fig. 11d) that drives the traction motor is due to the regenerative braking of the EV.

The electrodynamicometer load machine was driven by the Unidrive (Fig. 9) which was configured in servo mode to control the torque of the load motor. An analog signal produced by the NIUSB6211 electronic board was connected to the terminal 7 of the Unidrive which was configured as the input reference torque. The second Unidrive was programmed to work in the regenerative mode and its main function is to work as an inverter. The EV load profile was programmed in LabView.

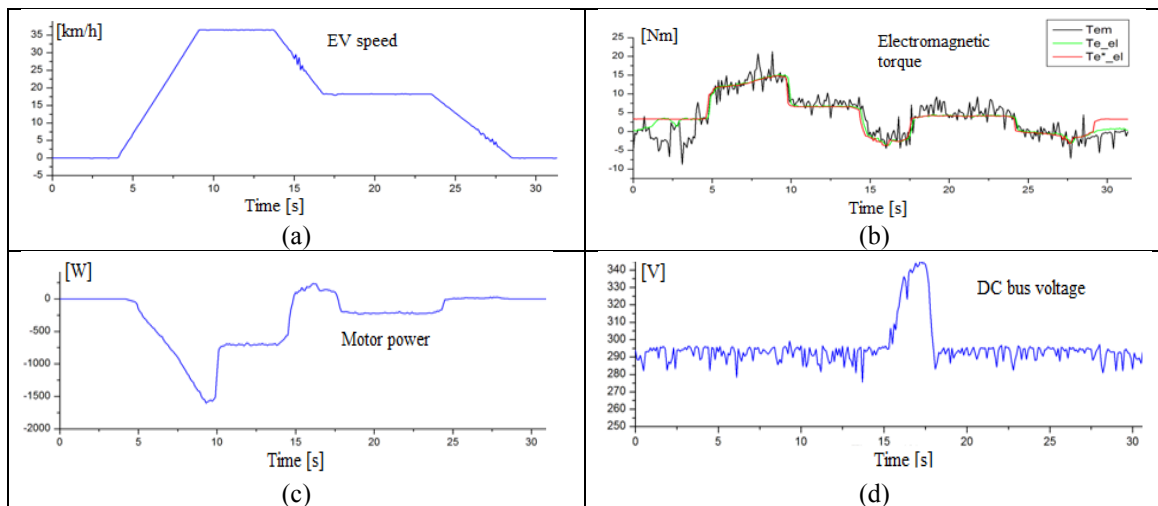

Figure 11: Experimental results obtained by using an electrodynamicometer (a) EV speed, (b) torque (c) motor power, (d) DC bus voltage

Fig. 12 illustrates the experimental results by using the EV. A 2000 rpm reference speed was set during nearly 7 s resulting in the acceleration of the EV, afterwards the reference speed is set to zero and the vehicle moves into the braking stage and it is finally stopped. Results of Fig.12

correlate well with the simulation results shown in Figs. 8b and 8c. Regenerative braking results with the energy flowing to the SCs were not available and are not included in this paper these will be presented in a further paper.

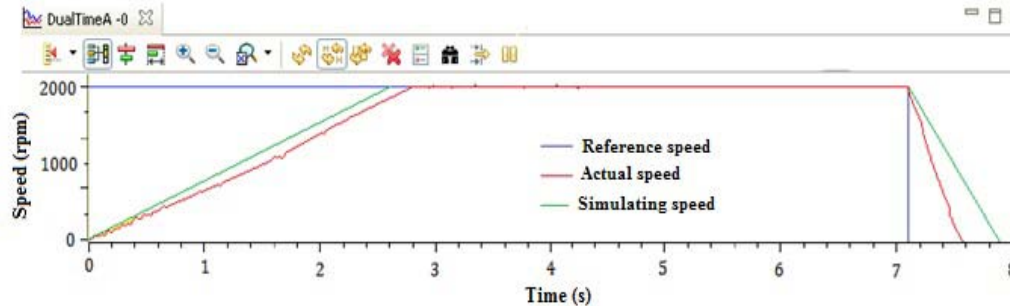

Figure 12: Resultados obtenidos con el EV durante la tracción.

7 Conclusions

This paper addressed the design, simulation and experimental validation of an EV which uses supercapacitors as the only energy source. The aim of the Project was to demonstrate the feasibility of using this type of electric transport in Mexico City. The SCs might be recharged during the time spent in the bus stop, that electric charge must be enough to allow the bus to reach the next stop where it is recharged again. Simulation results validate the motor control algorithms during the traction and regenerative stages. Experimental results were obtained by means of an electrodynamicometer where the EV parameters were programmed; some experimental results by using the EV are also presented.

Acknowledgments

This work was supported by the Institute of Science and Technology for Federal District (ICyTDF), México, under the project grant PICC 010-95.

8 Referencing

- [1] M. Ehsani, Y. Gao, E.E. Gay and A. Emadi, "Modern Electric, Hybrid Electric, and Fuel Cell Vehicles. Fundamentals, Theory and Design" CRC Press, 2005.
- [2] Z. Mihailovic, H. V. Prasad, and D. Borojevic, "Computer Modeling and Analysis of VSI Fed Permanent Magnet Synchronous Motor Drive Systems with Adjustable Levels of Complexity", APEC'97 Conference Proceedings, Vol. 2, pp. 728-735, 1997.

- [3] R. Krishnan, "Electric Motor Drives. Modeling, analysis and Control". Prentice Hall, 2001.
- [4] C. A. Espinoza-Arredondo, J.J. Rodriguez-Rivas and E.P. Sánchez, "Experimental Electrodynamicometer to Emulate Dynamic Performance of an Electric Vehicle", 2012 IEEE 27-th Convention of Electrical and Electronics Engineers in Israel, Nov. 14-17, 2012.

Authors



Edgar Peralta-Sánchez received the B.Sc. degree from the Benemérita Universidad Autónoma de Puebla, Puebla, Mexico, in 1994, the M.Sc. degree from the Universidad de las Américas-Puebla, Puebla, in 1999, and the Ph.D. degree in

electrical engineering from The University of Manchester, Manchester, U.K., in 2006. He was a Research Associate with the Power Conversion Group, School of Electrical and Electronic Engineering, The University of Manchester. He is currently a Lecturer with UPAEP, Puebla, México.



Jaime José Rodríguez Rivas. Received the B.E. from Universidad Central de Las Villas (UCLV), Cuba, in 1980 and M.S. and Ph.D. degrees in Moscow Power Institute, URSS, in 1987 and 1991 respectively. From 1980 to 1994 he was

Associate Professor of UCLV. Since 1996 he has been at National Polytechnic Institute in Mexico City, Mexico where he is currently Titular Professor and Researcher in the area of Power Electronics and AC Control Drives