

Different Novel Electric Machine Designs for Automotive Applications

Gurakuq Dajaku¹, Dieter Gerling²

¹*FEAAM GmbH, D-85577 Neubiberg, Germany, gurakuq.dajaku@unibw.de*

²*Universitat der Bundeswehr Muenchen, D-85577 Neubiberg, Germany, dieter.gerling@unibw.de*

Abstract

This paper presents three-different high efficiency and low costs electric machines types for automotive applications. For the PM machines with the single-layer concentrated windings, a novel stator topology with magnetic flux barriers in the stator teeth is used to increase the power density and the efficiency of the machine. Using this technique the material amount for the considered PM machine is reduced about 20% compared with the conventional design. For the asynchronous machines, two alternative solutions are presented; a new winding type with low space harmonic contents and also an ASM rotor with series connection of rotor bars solve the problem with high harmonics. Further, during the design of a new self-excited synchronous machine with concentrated winding, the high MMF winding harmonics are used to excite the rotor field winding.

Keywords: Concentrated winding, efficiency improvements, low costs, PM machine, self-excited synchronous machine, asynchronous machine

1 Introduction

In recent years, the requirements for better performances, safety, reliability, and lower cost and emissions in automobiles have driven the development of electrical machines using innovative materials and new design techniques. Depending on the application in automotive, there are different requirements and specifications which should be considered when choosing an electric motor, such as the wide speed operation range, torque density, efficiency, costs, maximal inverter current, limited DC voltage and limited space for packaging. Over the past several years permanent magnet (PM) synchronous machines have emerged as the best option to satisfy all these demands. Generally PM machines with fractional slot concentrated windings (FSCW) are widely used in the last time. The use of concentrated windings offers the advantage of short and less complex end-winding, high slot filling factor, low cogging torque, greater fault tolerance, and low manufacturing costs.

Of course, the use of PM synchronous machines with concentrated windings has not only advantages. Usually the permanent magnets are made of rare

material and the price for this material increase tremendously in the last time. On the other side, the concentrated windings are characterized with more space harmonics, including sub-harmonics, which lead to undesirable effects, such as eddy current loss in the magnets [1, 2], additional iron losses in rotor and stator core, and noise and vibrations [3, 4]. Hence, many researcher are trying to overcome the above challenges by adapting alternative machine topologies such as asynchronous machines (ASM) or current excited synchronous machines (CESM). Different from the PM machines, these machine types use usually distributed winding in the stator, and for the current excited synchronous machines they need additionally the brush-type exciter system for the rotor field winding. As well is known, the distributed winding is characterized with large end-winding length, high copper losses and high production costs compared with the tooth concentrated windings. Considering also the required additional space for the excitation system for the current synchronous machines, they represents the main drawbacks for these machine types for the application where the high power density, available volume, efficiency and the system

costs are all at a premium. Therefore, to overcome the presented problems and challenges, this paper presents three novel machine topologies; PMSM, ASM and CESM. For reducing the manufacturing costs the all machine types use simple tooth concentrated windings. Furthermore, the material amount for the PM machine is reduced up to 20% using a novel stator design with magnetic flux barriers. The problem with the winding sub- and the high harmonics by the asynchronous machine is solved using a new 36-teeth/10-poles winding, or with a proper rotor design. However, a novel self-excited synchronous machine concept solves the problems with the brush excitation system.

2 Concentrated Windings

A widely used tooth concentrated winding for the PM machines is illustrated in the following Fig. 1(a). Its stator winding differs from that of conventional PM machines in that the coils which belong to each phase are concentrated and wound on adjacent teeth, so that the phase windings do not overlap. For this winding type, the magneto motive force (MMF) space harmonics are shown in Fig. 1(b). As can be seen here, the 1st, 5th, 7th, 17th and 19th are the dominant space harmonics. For the 10-poles machine, however, only the 5th stator space harmonic interacts with the field of the permanent magnets to produce continuous torque. The other MMF space harmonics, in particular the 1st, 7th, 17th, etc., which have relatively large magnitude, are undesirable and in some cases they limit the usefulness of this winding type in different specific applications. In the case of an asynchronous machine excited with a certain frequency a number of torque and rotor bar loss components are generated at various slip based on the armature winding space harmonics. As results, the machine efficiency and the torque characteristics are too poor. However, for the current excited synchronous machine type, the winding MMF high harmonics induce additional losses and also AC-voltage components on the rotor field winding. To improve the MMF winding performances of the FSCW regarding to power losses and noise problems several methods and techniques are developed and investigated in the past [5 to 11]. In this paper three novel solutions are presented and their application on different machine types is demonstrated.

3 Low Costs and High Power Density PM Machine Design

Using concentrated windings, there are many possible slot number and pole number combinations for PM machines. The stator coils may be wound either on all the teeth (double-layer winding) or only on alternate teeth (single-layer winding). Single-layer

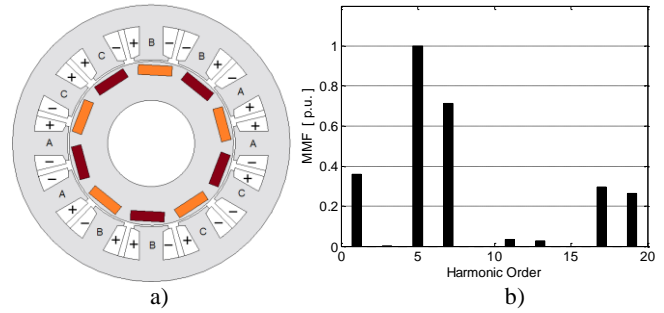

Fig. 1: a). The conventional 12-teeth/10-poles winding, b). MMF space harmonics.

windings are preferred to double-layer windings when a high fundamental winding factor and high fault-tolerance is required. However, for this winding type the amplitude of the 1st MMF sub-harmonic is relatively too high which induce huge losses in the rotor core and magnets and thus it decreases the torque density and the efficiency of the machine. As results, the single-layer windings rarely are used in the past for electric machines.

To improve the MMF winding performances for this winding type regarding to the sub-harmonics, a novel solution for reduction of air-gap flux-density sub-harmonics using magnetic flux barriers in specific stator teeth regions is presented in [9]. Fig. 2(a) shows the new stator design for a 14-poles PM machine with concentrated winding. In the considered example, the magnetic flux-barriers are located radially in the middle of teeth regions. Of course the realization and optimization of electric machines with the new stator can be performed in different ways such as using stator core with different teeth width and flux-barriers in alternate teeth, flux-barriers in all teeth, different shape for flux-barriers, stator modules with radial laminated and U-shape iron core and so on [9].

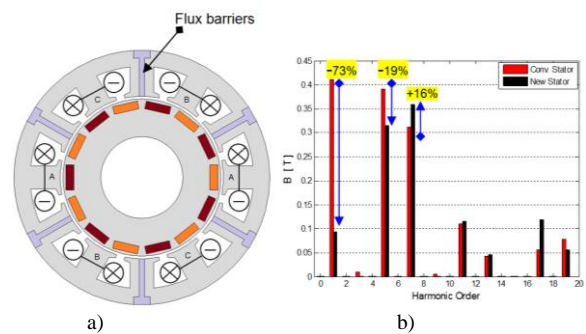

Fig. 2: a). The 12-teeth/14-poles PM machine with the new stator structure, b). Comparison of air-gap flux density harmonics due to stator currents.

To show the effect of the new method on the machine characteristics such as on the air-gap flux density harmonics, electromagnetic torque and power losses, two 14-poles PM machines with the single layer 12-teeth winding and with the conventional and also the new stator core are compared in following. To make a fair comparison, the both machine designs are

investigated under the same electrical and geometrical constrains (voltage, current and volume). Further, the same rotor design is considered for the both examples; the only difference on the machine geometries is the stator core (with- and without magnetic flux-barriers). The both machines are designed for maximal DC link voltage $U_{DC,max}=12$ V and the maximal rotor speed $n_{Max}=3000$ rpm. Further, the outer diameter and the active length of the studied machines are taken to be 80mm and 70mm, respectively. The presented simulation results in following are obtained using the finite elements method (FEM) and for $I_{eff} = 70A$ and $\delta = 20^\circ$ load condition (δ is current load angle).

From Fig. 2(b), comparing the air-gap flux density harmonics due to the reaction field under three-phase excitation and for the conventional and the new stator show enormous improvements on the flux density characteristics using the new technique:

- the 1st sub-harmonic is reduced by 73%,
- the 5th sub-harmonic is reduced by about 19%,

On the other side, the 7th working harmonic is increased by about 16%. As results, using the new stator topology the torque capability is increased for about 16% compared with conventional design, Fig. 3(a). Additionally, the torque ripples are also lower. Further, under the same load condition and for the rotor speed $n = 1200$ rpm, the machine losses are compared in Fig. 3(b). Also here, huge improvements on the machine losses are achieved. As results of sub-harmonic reduction the iron rotor losses are reduced for about 50%, however, the magnet losses for about 60%. The stator copper losses are the same since the simulations are performed under the same excitation condition.

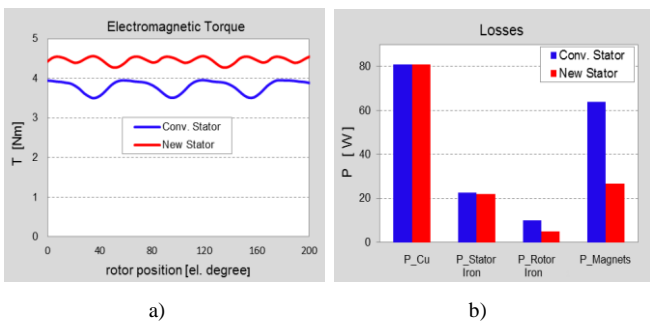

Fig. 3: Machine characteristics at $I_{eff}=70A$ and $n=1200$ rpm; a) Electromagnetic torque, b). Machine losses.

Furthermore, Fig. 4 shows the machine characteristics under the same torque capability condition. During this analysis, the active length for the convectional machine is taken to be the same as before (70mm), however, the active length for the new machine design is reduced for about 16% (58.8mm). The other electrical and geometrical constrains are taken the same. As well shown from Fig. 4, the both machines provides the same torque, however, with enormous loss reduction: 11.6% for copper losses, 17.5 for stator

iron losses, 58% for rotor iron losses, and 65% magnet losses. Of course, if the comparison is done for the same output power (mechanical power) the new machine design satisfies the requirements with an active length for about 20% shorter than the conventional design. Therefore, the new machine is characterized not only with high power density and high efficiency, however, the material amount for the rear earth magnets, copper and iron core can be reduced more than 15%. This leads to reduction in the motor costs and also in the machine volume and mass. An additional advantage for the new stator design is also the improvements on the field weakening capability. The simulation results given in the following Fig. 5 show a significant improvement on the electromagnetic torque and also the output power in the field-weakening region.

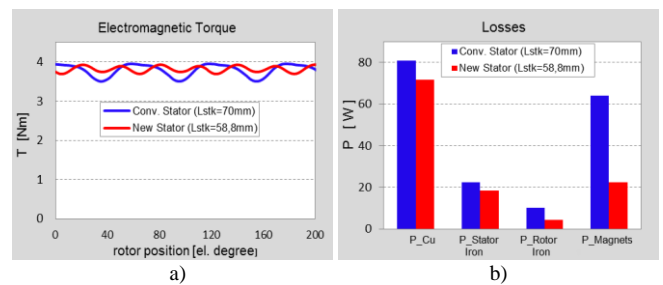

Fig. 4: Machine characteristics at $I_{eff}=70A$ and $n=1200$ rpm; a) Electromagnetic torque, b). Machine losses.

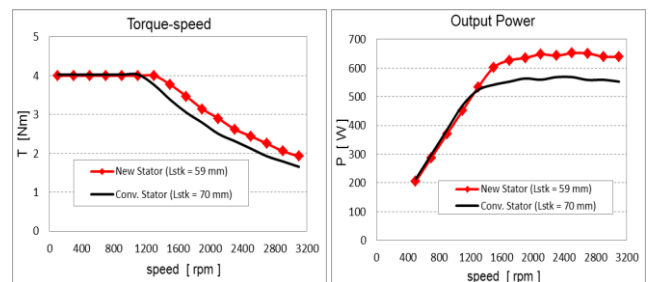

Fig. 5: Electromagnetic torque and output power vs. rotor speed.

4 New Self-Excited Synchronous Machine with Tooth Concentrated Winding

Different from the PM machines, by the current excited synchronous AC machines the field winding which is supplied with a DC current is used to generate the stationary magnetic field in the rotor. The direct current required for field excitation is furnished by the excitation system. Generally, two methods are commonly utilized for the application of the direct current to the rotor of a synchronous motor:

1. *Brush-type systems* apply the output of a separate DC generator (exciter) to the slip rings of the rotor,

2. *Brushless excitation* systems utilize an integral exciter and rotating rectifier assembly that eliminates the need for brushes and slip rings. The brushless excitation is called off as *self-excitation*.

The self-excitation method for the current excited synchronous AC machines is not new and widely is used by the wind power generators. Several patents are granted according to this excitation method [12, 13]. The concepts presented in these inventions are the same however they differ only on the realization. Generally, the stator contains two winding systems; the main three-phase winding which is usually a distributed overlapped winding, and an additional winding (auxiliary or field winding) to generate high harmonics in the air-gap. Since the both stator windings are located in the same stator core, they require a large stator volume for making place for the both winding systems. These winding must be good insulated to each other which leads to further decreasing of the copper filling factor and increasing also the stator manufacturing costs. Further, the stator field winding requires an additionally power supply device or rectifier bridge. On other side, the rotor consists also of two complex winding systems that in general increase the total costs of these machine types.

To overcome the drawbacks of the conventional self-excited synchronous machine, in [14] a simple brushless excitation concept using MMF winding high harmonics is presented. Fig. 6 to 8 show the basic block circuit diagram for the new machine concept and an 18-teeth/10-poles synchronous machine built according to this technique. The new machine design is characterized with simple tooth concentrated windings for the both stator and the rotor, and it doesn't need any additional axially winding in the stator and its corresponding power supply and control unit. The three phases **ABC** stator winding generate simultaneously the main working air-gap harmonic which is responsible for the electromagnetic torque, and also a specific high harmonic which is used for excitation of the rotor winding, Fig. 8. The rotor consists of two windings; the excitation winding **E** and the field winding **F**. When the rotor rotates, in the rotor excitation windings **E1** to **E5** there are induced electromagnetic forces the magnitude of which depends on the magnetic field of the air-gap high harmonics. The induced electromagnetic forces in the rotor excitation windings after are rectified by the diode bridge circuit, so that a direct current I_f flows in the field winding **F**. To avoid the high harmonics effect on the field winding, a special connection for the winding coils of the field winding is chosen.

Using the new machine concept, an 18-teeth/10-poles self-excited synchronous machine for electric vehicle application is presented in following. As typical requirements for the automotive traction drive

application, the following data are used: maximum DC-voltage $U_{DC}=400V$, maximum current $I_{max} = 600A_{rms}$ maximum short-time torque $T_{max}=270Nm @ 5100rpm$, and the available machine volume: $D_{Out}=230mm$, $L_{Stack}=150mm$. The design and analysis of the investigated machine is performed using finite elements method. The simulations results for the electromagnetic torque and the rotor field current for 500A stator current and at 5100 rpm rotor speed are given in Fig. 9. As well is shown, the machine torque for this operation point is

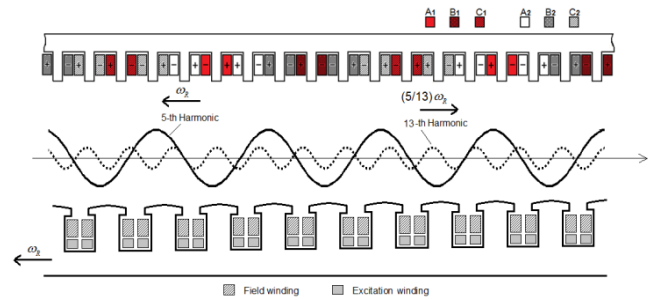

Fig. 6: Self-excitation concept for the 18-teeth/10-poled machine.

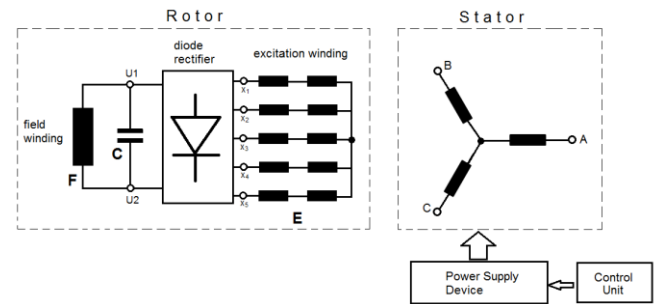

Fig. 7: Block circuit diagram for the new self-excited synchronous machine.

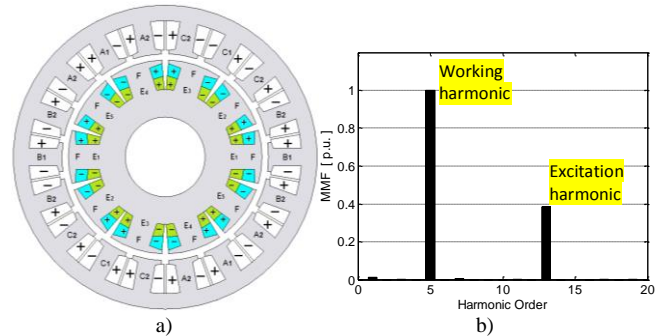

Fig. 8: a). Geometry of the new 18-teeth/10-poles self-excited synchronous machine, b). MMF space harmonics for the stator winding.

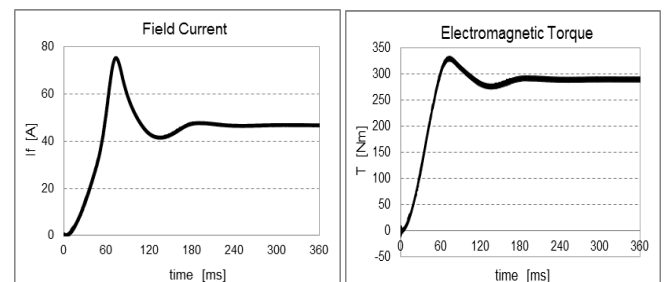

Fig. 9: Simulation results for $I_s = 500A$ and $n = 5100 rpm$.

about 290Nm, however, the rotor field current is 47 A. The obtained results for the electromagnetic torque response demonstrate the applicability of the new technique. Under the given load condition the designed machine generate the required maximal torque.

5 Different Asynchronous Machines with Concentrated Winding

Three-phase asynchronous machines commonly use single- or double layers, overlapping, distributed windings with $q \geq 2$ (q – is the number of coils per pole per phase). This winding configuration results in more sinusoidal magneto-motive force (MMF) and electromotive force (EMF) distributions, and hence, good machine performances. However, it is characterized with many drawbacks such as large end-winding length, overlapping coils, high number of stator slots per pole and low slot filling factor which are related with higher manufacturing and material costs, high copper losses and other end-winding parasitic effects.

On the other side, recently the fractional-slot concentrated windings (FSCW), or modular windings, have been gaining a lot of interest in PM synchronous machines. This is due to the several advantages provided by this type of windings which are mentioned previously. However, up to now there has been little to no interest in modular windings for rotary asynchronous machines. This is because modular windings do not produce high quality traveling fields (sinusoidal MMF). Different space harmonics of closely the same magnitude are produced that travel with different speed and in different directions which induce additional rotor currents and opposing torques with limited net torque and high rotor bar losses compared to a conventional distributed winding.

A. Novel 36-teeth/10-poles fractional slot winding for asynchronous machines

As well is mentioned above, the tooth concentrated windings even are characterized with several advantages concerning the production costs and packaging, due to the high harmonic contents until now they are unusable for the asynchronous machines. For reduction of the sub- and high MMF harmonic contents for these winding typed different techniques are developed in the past which are mostly applicable for the synchronous machines [5 to 11]. However, for asynchronous machine applications, a novel fractional slot 36-teeth/10-poles winding with low MMF harmonic contents is presented in [15]. Fig. 10(a) and (b) show the winding layout and the MMF winding harmonics, respectively. As well is shown, the coil-span for this winding type is two slot-pitches with the coil-span angle 20 degrees ($2 \times 360/36$). Comparing

with an analogous 10-poles distributed winding which has the coils-span angle 36 degree ($360/10$), the new winding is characterized with a shorter end winding length (about 45%), non-overlapping, and simple

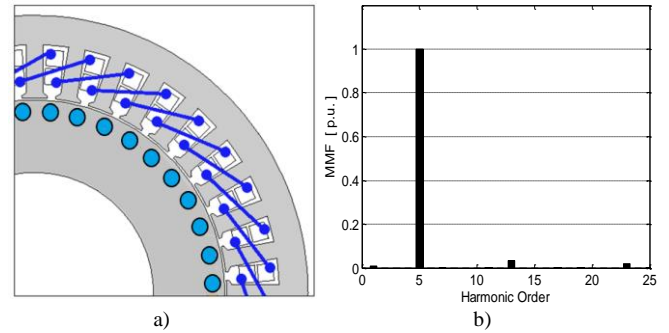

Fig. 10: New 36-teeth/10-poles winding; a). Winding layout, b). MMF space harmonics.

manufacturing.

In following, two different ASMs for the automotive traction drive application are designed under the given electrical and geometrical constrains: maximum DC-voltage $U_{DC}=200V$, maximum current $I_{max} = 240A_{rms}$ maximum short-time torque $T_{max}=200Nm @ 1300rpm$, and the available machine volume: $D_{Out}=300mm$, $L_{Stack}=85mm$. The first machine is designed using the conventional distributed winding with $q=3$ (q -is number of slots per pole per phase), however, the second machine is designed using the new 36-teeth/10-poles winding. The following Fig. 11 show the flux density distribution of the investigated machines under the high load condition.

During this study the considered machines are designed and optimized for two different conditions: efficiency improvements and the costs and volume reduction. The obtained results from this analysis show that with new ASM design the machine efficiency is improved up to 3% compared to the conventional design, however, if the machines are designed for the same efficiency condition, a weight reduction for the copper material up to 16% and total machine length reduction up to 5% is reached

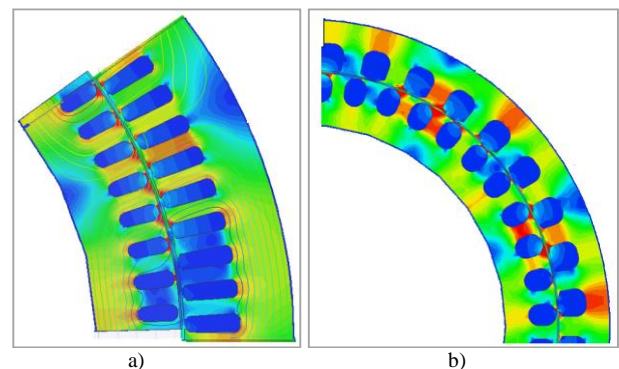

Fig. 11: a). Conventional 10-poles ASM with distributed winding with 90-teeth and 10-rotor poles, b).New 36-teeth/10-poles ASM.

with the new design.

A. ASM rotor with series connection of rotor bars

To allow the use of the conventional concentrated windings for the ASM machines, several techniques are developed in the past to reduce the MMF harmonics effect on the rotor winding, such as, using a multi-cage rotor [16] or the series connection of rotor bars [17]. The first method prevent the effect of a specific MMF harmonic or harmonics group on the rotor cage winding, however, using the second method it is possible to prevent completely the induction of the MMF harmonics on the rotor winding. In the following analysis the second technique is used during the design and analysis of an ASM with the 12-teeth/10-poles concentrated winding. Fig. 12 shows the ASM rotor with two rotor-bar systems and with series connection of rotor bars built according to the second method. Further, Fig. 13(a) and 13(b) show the geometry of the considered ASM and also the torque characteristics for the conventional rotor (with conventional end-rings) and the new rotor proposed. Further, the induced rotor-bar current and their corresponding Ohmic losses are given in Fig. 14. As well is shown from the obtained results, with the new rotor design the performances of the asynchronous machines with concentrated windings significantly are improved.

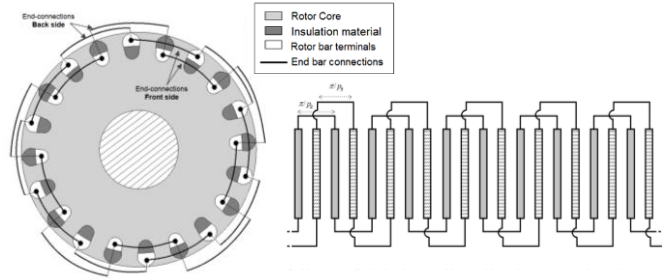

Fig. 12: ASM rotor with series connected rotor bars and two winding systems.

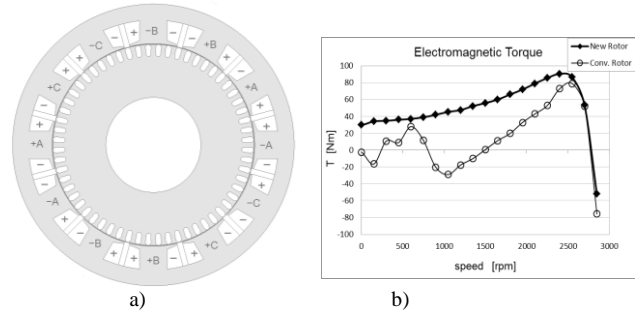

Fig. 13: a). Investigated 12-teeth/10-poles asynchronous machine, b). Torque characteristics for the conventional rotor and the new rotor.

6 Conclusions

Recently, fractional slot tooth concentrated windings are widely used for PM machines. The use of concentrated windings offers the advantage of short and less complex end-winding, high slot filling factor, low cogging torque, greater fault tolerance, and low manufacturing costs. Of course, the use these machines type has not only advantages. The high price for the magnet material, the demagnetization problems, and the negative effect of the winding space harmonics on the machine efficiency and noises are the main drawbacks of the PM machines with concentrated windings.

Therefore, to overcome the actual problems and challenges of these machine types, this paper presents three-different high efficiency and low costs methods for synchronous and asynchronous machines. For the PM machines with the single-layer concentrated windings, a novel stator topology with magnetic flux barriers in the stator teeth is used to increase the power density and the efficiency of the machine. Using this technique the material amount for the considered PM machine can be reduced up to 20% compared with the conventional design. For the asynchronous machines, two alternative solutions are presented; a new winding type with low space harmonic contents and also an ASM rotor with series connection of rotor bars solve

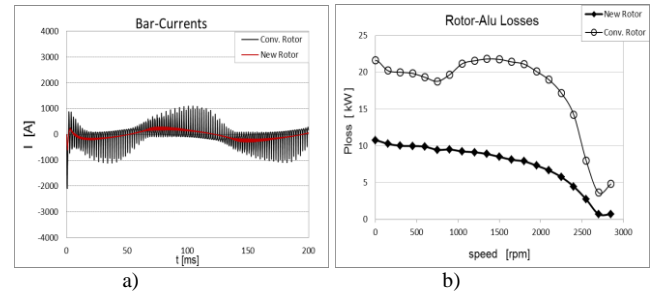

Fig. 14: a). Induced rotor-bar currents, b). Rotor-bar losses vs. rotor speed.

the problem with high harmonics. The new 36-teeth/10-poles ASM design show high capability on the efficiency improvements and also on the material costs reduction compared with an analogous ASM with the conventional distributed winding. However, the ASM rotor with series connected of rotor bars prevent the effect of most MMF harmonic on the rotor cage winding. Further, during the design of a new self-excited synchronous machine with concentrated winding, the high MMF winding harmonics are used to excite the rotor field winding. The new CESM designed according to this technique is characterized with high power density, inexpensive, robustly, and very compact.

References

[1] Magnussen F., Sadarangani Ch.: "Winding factors and Joule losses of permanent magnet machines with concentrated windings". 2003 IEEE International Electric Machines & Drives Conference (IEMDC 2003), 01-04.06 Madison Wisconsin, USA.

- [2] N. Bianchi, E. Fornasiero: "Index of rotor losses in three-phase fractional slot permanent magnet machines". *Electric Power Applications, IET*, vol. 3, No. 5, September 2009.
- [3] J. Wang, Zh. P. Xia, D. Howe, S. A. Long : "Vibration Characteristics of Modular Permanent Magnet Brushless AC Machines". *IEEE IAS Annual Meeting, 2006, Tampa, Florida, USA*.
- [4] J. Krotzsch, B. Piepenbreier: "Radial Forces in External Rotor Permanent Magnet Synchronous Motors with Non-Overlapping Windings ", *IEEE Transactions on Industrial Electronics*, Vol. 59, No. 5, pp. 2267-2276, May 2012.
- [5] H. Kometani, Y. Asao, K. Adachi: "Dynamo-electric Machine", US Patent 6,166,471, Dec. 26, 2000.
- [6] M. V. Cistelecan, F. J. T. E. Ferreira: "Three phase tooth-concentrated multiple-layer fractional windings with low space harmonic content", *IEEE on Energy Conversion Congress and Exposition (ECCE) 2010*.
- [7] G. Dajaku, D. Gerling: "Eddy Current Loss Minimization in Rotor Magnets of PM Machines using High-Efficiency 12-teeth/10-poles Winding Topology", *International Conference on Electrical Machines and Systems (ICEMS-2011)*, 20.-23. August 2011, Beijing, China.
- [8] G. Dajaku, D. Gerling: "A Novel 12-Teeth/10-Poles PM Machine with Flux Barriers in Stator Yoke", *20-th International Conference on Electrical Machines (ICEM'2012)*, 02.-05. September 2012, Marseille, France.
- [9] G. Dajaku, D. Gerling: "Low Costs and High-Efficiency Electric Machines", *2nd International Electric Drives Production Conference 2012 (EDPC-2012)*, 16.-17. October 2012, Erlangen-Nürnberg, Germany.
- [10] G. Dajaku, D. Gerling: "A Novel Tooth Concentrated Winding with low Space Harmonic Content", *International Electric Machines and Drives Conference (IEMDC-2013)*, Chicago, IL, USA, May 12-15, 2013.
- [11] E. Farnasiero, L. Alberti, N. Bianchi and S. Bolognani: "Considerations on selecting fractional-slot windings", *Energy Conversion Congress and Exposition (ECCE)*, 2010 IEEE, pp. 1376-1383, 12-16 Sept. 2010.
- [12] Platzer H., Brushless Synchronous Generator System, US 4121148, 1978.
- [13] Kenji I., Takayuki F., Brushless Self-Excitation Synchronous Electric Motor, JP 3245755, 1991.
- [14] G. Dajaku, D. Gerling: "New Self-Excited Synchronous Machine with Tooth Concentrated Winding", *3rd International Electric Drives Production Conference 2013 (EDPC-2013)*, Erlangen-Nürnberg, Germany (paper accepted).
- [15] G. Dajaku: "Elektrische Maschine", German patent application No. DE 102013 103665.1.
- [16] Clovis E. Linkous: *High efficiency induction motor with multi-cage rotor*, United States Patent, US 3987324.
- [17] *Induktionsmaschine*, Austrian Patent, AT 220226B.

Authors



Gurakuq Dajaku; Dr.-Ing. Gurakuq Dajaku is with FEAAM GmbH, Werner-Heisenberg-Weg 39, D-85579 Neubiberg, Germany (phone: +49 89 6004-4120; fax: -3718; Email: gurakuq.dajaku@unibw.de).

Born in 1974 (Skenderaj, Kosova), got his diploma degree in Electrical Engineering from the University of Pristina, Kosova, in 1997 and his Ph.D. degree from the University of Federal Defense Munich in 2006. Since 2007 he is Senior Scientist with FEAAM GmbH, an engineering company in the field of electric drives. From 2008 he is a Lecturer at the University of Federal Defense Munich. His research interest is in the field of electrical machines and drives. He has published numerous technical papers in different IEEE Journals and Conferences and has several international patents and patent pending applications.

Dr. Dajaku receive the Rheinmetall Foundation Award 2006 and the ITIS (Institute for Technical Intelligent Systems) Research Award 2006.



Prof. Dr.-Ing. Dieter Gerling

Institute for Electrical Drives, University of Federal Defense Munich, Werner-Heisenberg-Weg 39, 85579 Neubiberg, Germany
Tel: +49 89 6004 3708, Fax: +49 89 6004 3718

Email: dieter.gerling@unibw.de
URL: www.unibw.de/EAA

Born in 1961, Prof. Gerling got his diploma and Ph.D. degrees in Electrical Engineering from the Technical University of Aachen, Germany in 1986 and 1992, respectively. From 1986 to 1999 he was with Philips Research Laboratories in Aachen, Germany as Research Scientist and later as Senior Scientist. In 1999 Dr. Gerling joined Robert Bosch GmbH in Bülh, Germany as Director. Since 2001 he is Full Professor and Head of the Institute of Electrical Drives at the University of Federal Defense Munich, Germany.